

EFFECT OF USING DISSOLVED AIR FLOTATION SYSTEM ON INDUSTRIAL WASTEWATER TREATMENT IN PILOT SCALE

YAHYA HABIBZADEH*, K.B.GURBANOV**

**University of Applied Sciences & Technology Tabriz (Iran)*

***Institute of Physics of Azerbaijan National Academy of Sciences*

Baku, Az-1143, H. Javid ave.,33

In the present paper the application of Dissolved Air Flotation (DAF) system for wastewater treatment, especially for industrial wastewater on a designed pilot system has been investigated. It is for the first time in dissolved air flotation system that instead of air dissolving tube, hydro cyclone technology is used to dissolve air in water with ratio of 1:1 (almost 100%) in the form of small air bubbles and a circular flotation tank instead of rectangular tank. The advantage of usage of circular tank in DAF system is the capability of being treated in higher rate of mass, so less space is needed. Although application of hydro cyclone with different diameters of holes for producing mixing energy which also has the capability of direct injection of chemical coagulant and polymeric materials leads to the higher efficiency of treatment and so reduces the cost of pump and consumed air.

Investigations on the efficiency of this system was done by providing and analyzing samples of wastewater with and without adding of PAC (Poly Aluminum Chloride). Sampling and analyzing was done according to standard methods. The results of the analyses show that pilot system has high efficiency, especially for oil removal.

1. INTRODUCTION

Nowadays importance of environmental problems has increased which leads to establishment of stricter environmental standards and according to these standards more limits are applied on pollution caused by wastewater of industrial units. Considering the large amount of these wastes, it is necessary to find new technologies with higher efficiency for treatment of wastewater to satisfy new standards. These new systems in spite of their

high technology and efficiency should need less space and have lower cost, so even small industrial units can take advantage of these systems [1].

Because of the existence of suspended solids and stable fats emulsion in industrial wastewater, its treatment is technically difficult. Conventional treatment process consists of physical, chemical and biological steps. In the first step of treatment process which is physical treatment, floating or settled materials are removed by screening or sedimentation. Chemical and biological treatments are carried out as second step of treatment process which removes most kinds of the organic material from waste water. As the last and third step of treatment some other processes such as adsorption and electro coagulation (EC) units are used to reduce the amount of pollutants like nitrogen, phosphorus, metals and so on.

In physico-chemical treatment for more, fast and better removal of suspended organics, minerals and oily materials and forming larger flocs, coagulants and polymers (flocculents) are used and then these flocs can be separated and removed from waste water by applying sedimentation, filtering or flotation methods [1,2].

DAF (Dissolved air flotation) system is known as an economic and efficient system compared to other conventional clarification systems in the field of treating industrial and recently municipal wastewater during the last 35 years. Solid particles, fat and oily materials in DAF system are removed very fast and sludge obtained from this system is of high consistency. DAF system can be used as a process for removing finest suspended particles. Air dissolved in water forms small bubbles that contact suspended particles in water so by decreasing their density these particles gain enough energy to be floated. For increasing the efficiency of flotation system chemical

additives (coagulants) are used, these additives form flocs which leads to better flotation due to collisions of these flocs and small bubbles [1,3].

The results of a case study done by S. M. J. Hoseyni on wastewater of paper mill (wastewater with fibers, hot press and mixed wastewater) using DAF system for flotation with rectangular tank and air dissolving tube, shows that the best efficiency for treatment of wastewater with fibers is reached at pressure of 3 bar and retention time of 15 min. In this situation the results of treatment is 40% for suspended particles, 10% for TSS (Total suspended solid) and 16.6% for COD (Chemical oxygen demand). In the wastewater of hot press at pressure of 5 bar and retention time of 15 min, the results of treatment is 45% for suspended particles, 6.5% for TSS and 29.75% for COD and in the wastewater of mixed at pressure of 4 bar and retention time of 15 min, the results of treatment is 38% for suspended particles, 10% for TSS and 17.3% for COD. In this study the effect of adding lime and alum was investigated which shows removal of 28% of COD from mixed wastewater and 23-28% from wastewater with fiber and without any effect on wastewater of hot press [3].

In a research done by Miller, Morse and Colic in spite of investigating on different flotation methods there are acceptable results approving the efficiency of hydro cyclone with rectangular flotation tank in different wastewaters [4].

TSS and COD of several different kinds of wastewaters treated by DAF system are compared in table1.

Table1: Comparison of TSS and COD [4]

	TSS before (ppm)	TSS after (ppm)	COD before (ppm)	COD after (ppm)
Seafood processor	28000	150	62000	12000
Rendering plant	25000	80	67000	13000
Food processing	1500	35	12000	3000
Laundry	5500	5	24000	3500
Municipal	285	50	320	180

Papageorgiou and et al in wastewater treatment of an olive oil extraction factory, gained 10.8% efficiency in COD

removal without using any chemical additive but by adding sulfuric acid (PH=2) and lime (PH=11) efficiency increased to 30% and 24.5% respectively [5]. Parker used DAF for oil industry's wastewater treatment and get to 58% and 57% efficiency in TSS and TVSS (Total volatile suspended solid) removal respectively, he also removed 74% of oil and grease from wastewater using this system [6]. Jarsarayi using physical and chemical (Aluminum sulfate and lime) processes for treatment of wastewater with fibers in paper mill got to 45-55 percent in COD and 75-95 percent in color removal efficiency, he also got to 45-55 percent in COD and 75-95 percent in color removal efficiency in the case of alkaline wastewater. Adding 2.5 g/lit of lime or 0.4 g/lit Alum to these wastewaters leaded to 55% in COD and 90% in color removal efficiencies [2].

2. DISSOLVED AIR FLOTATION SYSTEM BY HYDRO CYCLONE

An important matter in flotation method, is the introduction of air bubbles into water. In early flotation machines larger air bubbles (2-5mm) are formed by blowing air through a canvas or other porous medias. In some impller-based machines, air enters system directly from atmosphere and no compressor or blower is necessary, bubbles produced by this method are coarse, so this method is not suitable for flotation in wastewater treatment and oil extraction.

DAF is another method for flotation, which usually is used for oily wastewater treatment. In DAF system, stream of wastewater is saturated with air at elevated pressures up to 5 atm. Small bubbles which are formed in DAF system, are brought into contact with continuously flowing particles. Having such small bubbles (up to 20 microns) may cause some problems. Bubbles formed in DAF system rise very slowly to the surface of the

tank, this is the reason of using tanks with large dimitions in DAF system. Air-to-water ratio even at high pressures is very low, air-to-water ratios of 0.15:1 by volume are common in DAF systems and it is difficult to achieve higher ratios. Some of these problems are solved by new higher technologies like air sparged hydro cyclone coupled with a porous cylinder. Inffluent enters hydro cyclone from side of it and in the entrance a spiral flow forms which causes a centrifugal acceleration. Air enters hydro cyclone from its top, gas entering the pipe produces bubbles in it which are floated in centrifugal flow field due to radial acceleration gradient that affects vortex caused by hydro cyclone. Bubbles accelerate towards inner surfaces of spiral layer. Centrifugal flow field in spite of forming angular acceleration, assists the classification of particles with different density in water. Although retention time of liquid in bubble chamber is only a few cent seconds but for its high acceleration, bubbles cover this short distance in vortexes in a few milliseconds. In this short time bubbles contacting particles moving towards porous cylinder form flocs of particle/bubble (colloids).

Another advantage of air sparged is cleaning of porous cylinder and preventing its malformation and sedimentation. Velocity of gas transmission in this system is very high and formed bubbles are fine and floated, this improves separation of volatile organic and aeration of water. The last step of treatment takes place in the flotation tank, flocs of polymer/particle/bubble are formed in bubble

chamber of hydro cyclone before being fed to flotation tank. This tank is a place for separation of particles from wastewater, not for collision of bubbles and particles. Hydro cyclone system responds very fast to chemical reactions (seconds against hours). This becomes more useful when the entering water has variable compound and needs to be adjusted fast. Regarding high efficiency of hydro cyclone in pilot system that provides needed energy for mixing under the influence of centrifugal forces, this system (hydro cyclone system) is used for adding coagulants and flocculants to wastewater too, leading to formation of flocs. As it was mentioned, bubbles formed in hydro cyclones are more finer and smaller than bubbles of conventional DAF systems, that is due to shear force applied on bubbles by centrifugal force. Smaller bubbles and more mixing energy in hydro cyclones makes the mixing process more effective and shortens its time compared to conventional DAF systems. Desired chemicals are added to wastewater in the entrance of cylinders because mixing takes place in these columns. Chemical materials are prepared and agitated in special tanks and each material is added in a separate hydro cyclone unit, so the number of hydro cyclones should be the same as the number of chemical materials. To have the best operation, each chemical needs definite mixing energy depending on its molecular configuration so the nozzles of hydro cyclone have holes with different diameters.

With varying the diameter of holes, the velocity of fluid entering to hydro cyclone changes which leads to the variation of mixing energy. The number of holes can be changed by using a filled bush. Gaining the best mixing energy is possible by try and error [4].

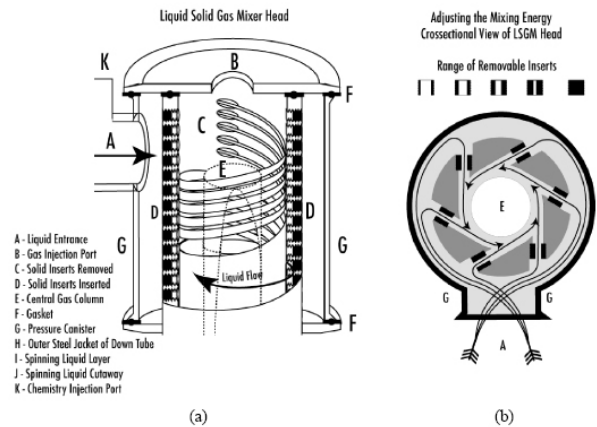

Fig.1. Cut-away view of (a) liquid solid gas mixer head (b)cross-sectional view of a liquid solid gas mixer head [4]

3. RESEARCH METHOD

3.1. Description of process

Pilot system was designed after initial studies to provide needed equipments for taking necessary samples. The schematic of the designed system is demonstrated at figure2.

In the pilot system wastewater enters equalization tank after passing through screen and then it is pumped to hydro cyclone where air and chemicals are added to it, this wastewater containing particles/air/chemicals is fed to flotation tank and in this tank, floating solids are scraped by a spiral scoop. Wastewater leaving this tank enters level

control tank by two pipes, in this tank the level of treated wastewater in flotation tank and the thickness of scraped sludge form flotation tank can be adjusted. There is a tank in the bottom of flotation tank for gathering settled sludge, finally the sludge of this part is discharged to sludge storage tank.

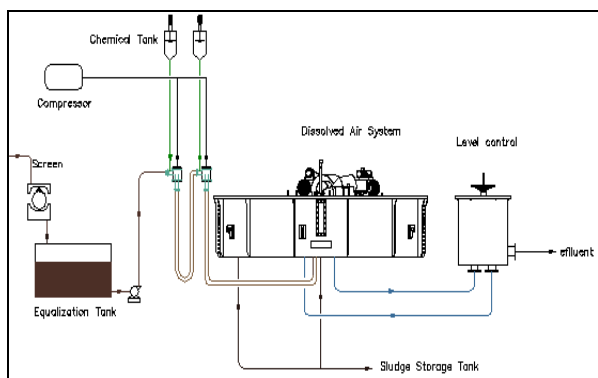

Fig. 2. Schematic of the designed equipment

3.2. Design of systems used in pilot

Designed pilot consists of DAF, electro coagulation, ozonation and excess chrome separation units. Figure3 shows three dimensional view of the arrangement of designed pilot system containing all above mentioned units.

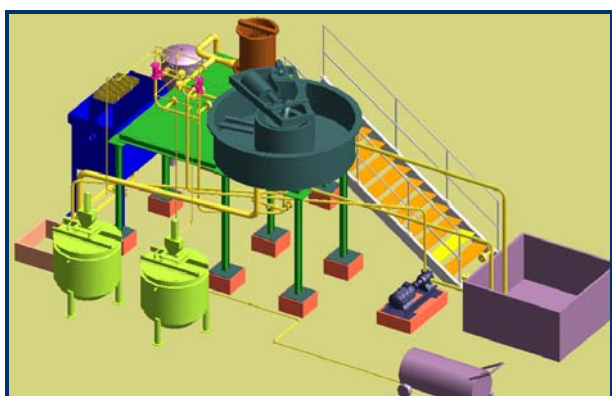

Fig.3. Three dimensional view of the arrangement of pilot

The assemblage process of pilot system in SPS Co. is shown at figure4.

In this study we have focused on the effect of DAF system with circular flotation tank and one hydro cyclone unit, the effect of adding PAC (Poly Aluminum Chloride) is investigated too. Other units and their effect on industrial wastewater treatment will be analyzed in future studies.

Pilot system is designed according to the DAF system of reference 4, but we have used circular flotation tank (figure 5) in our pilot system instead of rectangular one that is used in reference 4.

Some advantages of circular flotation tanks are:

- Retention time: Minimum
- Purchase cost: Lower than other systems of comparable performance
- Installation cost: Low, heavy support not needed
- Space requirement: Minimal
- Cleaning: Easy, bottom is self cleaning



Fig.4. Assemblage process of pilot system

Finally the most important advantage of circular tanks is their capability of handling more influent flow compared with rectangular tanks.



Fig.5. Circular flotation tank of pilot system

Different parts of pilot system, used in recent research are explained in the following.

3.2.1. Screen

To protect systems placed in downstream of flow like pumps and other accessories and also to prevent clogging of holes of hydro cyclone system a screen is used to remove big solids.

3.2.2. Volume of equalization tank

To have an equalized, steady flow of wastewater, it is fed to a tank with the name of equalization tank and after spending retention time, it is send to main parts of DAF system. The volume of this tank is calculated as following.

$$V (m^3) = Q (m^3/hr) \times T (hr) \quad (1)$$

Where Q is the flow rate of entering wastewater ($Q = 2 m^3/hr$) and T is retention time of wastewater in the tank ($T = 2.5 hr$).

So the volume of tank is:

$$V = 2 m^3/hr \times 2.5 hr = 5 m^3$$

To prevent sepsis of wastewater it should be aerated and for better mixing and keeping aerobic condition, surface aeration in the form of agitation is used.

3.2.3. Rotating clarification unit of DAF

To separate flocs of solids/air/coagulants formed in hydro cyclone from wastewater, it enters a tank. This tank is known as floatation tank and like conventional DAF systems of this company, is designed in circular form (figure6). Wastewater send to floatation tank contains solids and flocs that after scraping of them by spiral spoon, floated wastewater is send to next step. In the pilot system designed for this investigation to have the best efficiency circular tank combined with spiral spoon is used. Sludge of floatation tank that consists of scraped floated solids and settled material enters sludge storage tank.

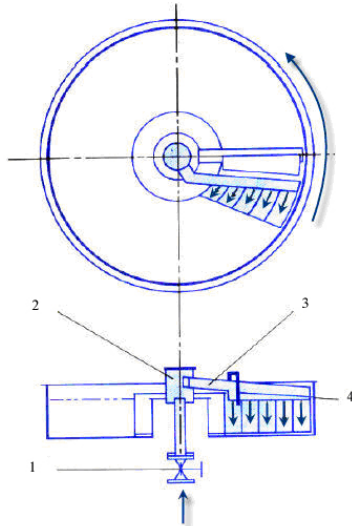

Fig.6. Schematic of floatation tank

Treated water discharged from floatation tank, is fed to level control tank. In this section fluid flows by gravity and no pump is needed. In conventional non rotating systems fluid flows from inlet to outlet but in DAF system inlet and outlet are centrally rotating so during clarification the velocity of water becomes zero. This means that the efficiency of clarification increases to theoretically maximum efficiency level. According to figure6 non clarified wastewater passes through valve (1) and then gets to central cylinder (2) which plays the roll of a collector, after this part wastewater is fed to inlet head box (3). Excess air is discharged from wastewater by a pipe (4).

The volume of floatation tank can be calculated using relation1 with Q of $2\text{m}^3/\text{hr}$ and retention time of 4min.

$$V = 2 \text{ m}^3/\text{hr} \times 4 \text{ min} = 0.133 \text{ m}^3$$

The floatation tank of pilot system after starting_the system is shown at figure7.

For calculating the volume of needed air per hour, we should know that the maximum efficiency of dissolved air flotation systems can be reached when the percentage of injected air volume is about 2-3 percent of wastewater's volume. So for Q of $2\text{m}^3/\text{hr}$ we have:

$$V_{\text{air}} = 2 \text{ m}^3/\text{hr} \times 0.03 = 0.06 \text{ m}^3/\text{hr}$$

$$V_{\text{air}} = 2 \text{ m}^3/\text{hr} \times 0.02 = 0.04 \text{ m}^3/\text{hr}$$

3.2.4. Hydro cyclone

Air enters hydro cyclone from gas injection port on the top of hydro cyclone and wastewater enters tangentially from side of it marked with (a) in figure8. Cross section of hydro cyclone is shown at figure8. Tangential entrance

forms a spiral fluid flow causing a centrifugal acceleration (figure9).

Compressed air passes through central gas column of hydro cyclone and produces fine bubbles under the influence of radial acceleration gradient. All parts of hydro cyclone are made from stainless steel. To control mixing energy of wastewater and chemicals, nozzles with different diameters are used, one of these nozzles is marked with (b) in figure8. Hydro cyclone designed for installation on pilot system can be seen in figure10.



Fig.7. Floatation tank of pilot system after starting the system

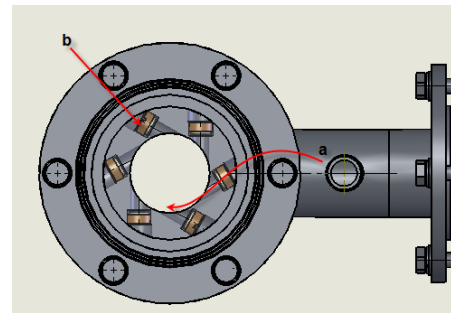

Fig.8. Cross section of hydro cyclone

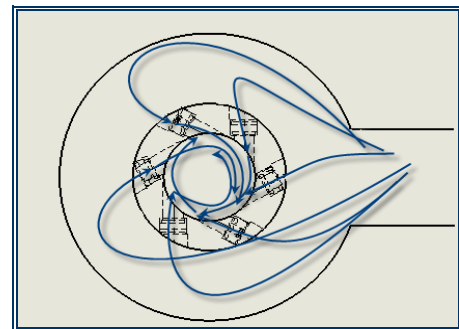

Fig.9. Schematic of tangential flows entering hydro cyclone



Fig.10. Hydro cyclone installed on pilot system

For calculating the diameter of nozzles of hydro cyclone, relations of mixing energy and equations of continuity are used. Diameters are calculated for velocity gradients (G) in range of 250 1/s to 1500 1/s which is suitable for fast mixing operation according to reference1. For G of 1500 1/s nozzle diameter is calculated as following:

$$\text{Maximum mixing energy} \Rightarrow G = 1500 \frac{1}{s}$$

$$\text{Vol. of hydro cyclone's cylinder: } \bar{V} = \frac{\pi}{4} \times (D)^2 \times L \quad (2)$$

Where D is diameter of hydro cyclone's cylinder and L is its height. Replacing these values in relation2, volume of cylinder becomes:

$$\bar{V} = \frac{\pi}{4} \times (0.15)^2 \times 0.25 \Rightarrow \bar{V} = 4.4 \times 10^{-3} m^3$$

$$\text{Mixing energy: } G = \sqrt{\frac{P}{\mu \times \bar{V}}} \quad (3)$$

In relation3, μ is dynamic viscosity (N.s/m²), \bar{V} is the volume of cylinder calculated before and P is the power lost of effluent leaving nozzle that should be calculated in this relation, replacing known parameters in relation3 we have:

$$\Rightarrow 1500 = \sqrt{\frac{P}{10^{-3} \times 4.4 \times 10^{-3}}} \Rightarrow P = 10W$$

The relation among P (W), γ (kN/m³), Q (m³/hr) and h (m) is demonstrated in relation4:

$$P = \gamma \times Q \times h \quad (4)$$

Where h is the head lost of effluent passing through nozzle and can be calculated using relation5:

$$h = \frac{kV^2}{2} \quad (5)$$

In relation above k is constant and in this case it equals 1 and V is the velocity of effluent leaving nozzle that is unknown and should be calculated using relations 4 and 5 as following:

$$\Rightarrow 10 = 10000 \times \frac{2}{3600} \times 1 \times \frac{V^2}{2} \Rightarrow V = 1.9 m/s$$

Now we can find diameter of nozzle (d) by using relation6, knowing velocity of leaving effluent ($V=1.9$ m/s), effluent flow rate ($Q= 2$ m³/hr) and the number of nozzles ($n= 48$):

$$Q = n \times \frac{\pi d^2}{4} \times V \quad (6)$$

$$\Rightarrow \frac{2}{3600} = 48 \times \frac{\pi d^2}{4} \times 1.9 \Rightarrow d = 2.8mm$$

For minimum mixing energy (with G of 250 1/s) and the same volume of cylinder, μ and number of nozzles, new value of P can be calculated using relation3:

$$\Rightarrow 250 = \sqrt{\frac{P}{10^{-3} \times 4.4 \times 10^{-3}}} \Rightarrow P = 0.275W$$

Now V can be calculated by means of relations 4 and 5:

$$\Rightarrow 0.275 = 10000 \times \frac{2}{3600} \times \frac{V^2}{2} \Rightarrow V = 0.32 m/s$$

Finally the diameter of nozzle (d) is calculated using relation6:

$$\Rightarrow \frac{2}{3600} = 48 \times \frac{\pi d^2}{4} \times 0.32 \Rightarrow d = 7.0mm$$

Diameters of nozzles of hydro cyclone for fast mixing, according to previous calculation vary among 2.8 and 7 mm, and five nozzles of different diameters are demonstrated in figure11, but only two size of nozzles are used in this paper. These nozzles can easily be installed on and uninstalled from hydro cyclone. The material of these nozzles is phosphorous brass.



Fig.11.Nozzles of hydro cyclone with different diameters

4. RESULTS

Industrial wastewater used in this study has been taken from food processing industry, samples of wastewater were treated during steps explained before. Used coagulant was Poly Aluminum Chloride (PAC), prepared with necessary consistency in tank of chemical materials and then is pumped by a dosing pump. According to executed jar test the best doze of PAC with PH of 6.95 is 30 ppm for the wastewater used in this study.

In usage of additive chemicals in spite of their effect on coagulation, the effect of them on flocculation should be considered too, those chemicals with lower molecular weight like PAC are mostly used as coagulant and need more mixing energy (smaller diameter of nozzles of hydro cyclone) but chemicals with higher molecular weight like long chained polymers that are suitable for flocculation need less mixing energy (bigger diameter of nozzles of hydro cyclone).

In this study just one hydro cyclone is used for adding PAC and for future researches another hydro cyclone is considered for adding polymer as flocculent. Although we have used only PAC as coagulant, considering its little effect on flocculation, the results are acceptable.

For detailed analysis, sampling was done in two steps with and without adding PAC and each time with two different diameters of nozzles. Sampling and analyzing was carried out according to standard methods for measuring the amount of COD, TSS, Oil and PH in wastewater.

The results of analyses are presented in tables2 and 3 respectively for steps without and with adding PAC.

Table2: Results of samples analyses without adding PAC

Sample No.	Sample 1	Sample 2	Sample 3
PH	6.95	6.80	6.40
COD	23470	17784	14046
TSS	830	460	380
Oil	272.7	174.6	167.2

Table3: Results of samples analyses with adding PAC

Sample No.	Sample 1	Sample 4	Sample 5
PH	6.95	6.45	6.20
COD	23470	10940	7820
TSS	830	320	160
Oil	272.7	85.4	81.2

Sample1 is the wastewater being fed to pilot system which is taken from equalization tank. In Samples 2 and 3, no PAC is added and diameters of nozzles are respectively 7 and 3 mm. The effect of adding PAC is investigated by taking samples 4 and 5 with nozzle diameters of 7 and 3 mm respectively. Samples 2, 3, 4 and 5 are taken from level control tank.

It should be mentioned that these diameters are selected to search on the effect of mixing energy on efficiency of treatment. According to presented calculations with diameter of 7 mm the mixing energy is minimum and it is maximum for diameter of 2.8 mm, but because of machinery problems nozzle with diameter of 3 mm is used instead of 2.8 mm.

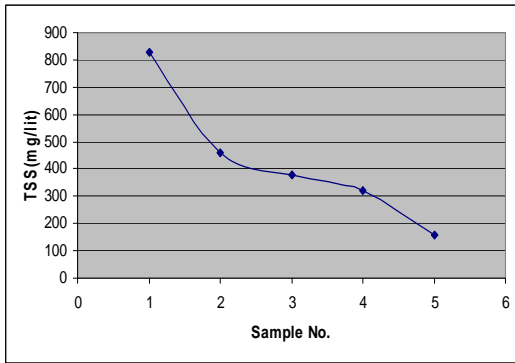

Diagram 1: TSS value of samples

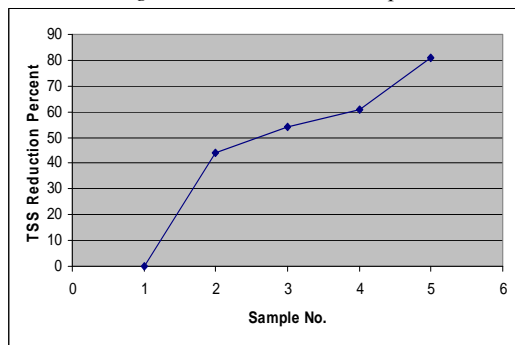

Diagram 2: TSS reduction percent

As shown in diagram1, TSS has decreased from 830 mg/lit to 380 mg/lit in sample3 and adding PAC makes its value 160 mg/lit in sample5. In diagram2, reduction percent of TSS is demonstrated, which is 81% in sample5. Diagram3 shows COD value before and after adding PAC. Diagram4 shows COD reduction percent, its value is 67% in sample5. According to diagram5 oil content of samples has decreased from 272.6 mg/lit in sample1 to 167.2 mg/lit in sample3 and it decreases to 81.2 mg/lit in sample5 by adding PAC. Diagram 6 demonstrates that oil reduces to 70.2% in sample5, this means that adding PAC is very effective for reducing oil. Adding PAC hasn't a

considerable effect on PH reduction, according to diagram7.

Finally according to the results this system can be offered for pre treatment of industrial wastewater.

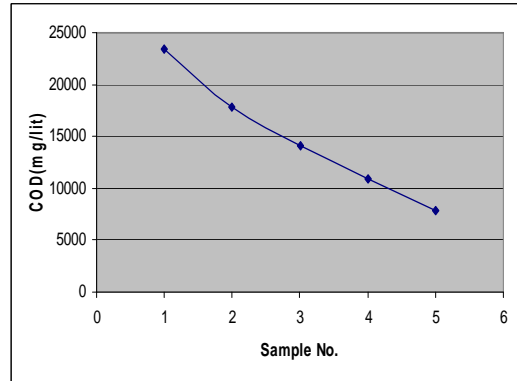

Diagram 3: COD value of samples

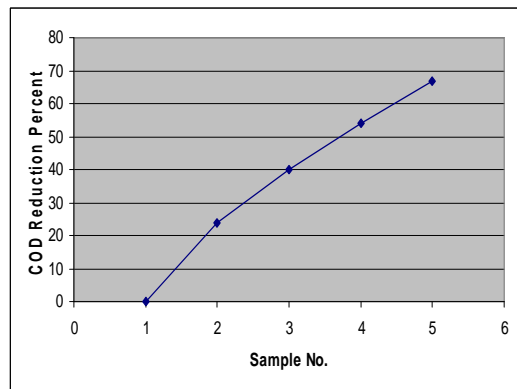

Diagram 4: COD reduction percent

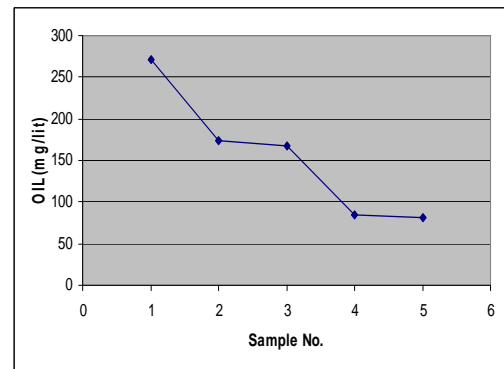

Diagram 5: Oil content of each case

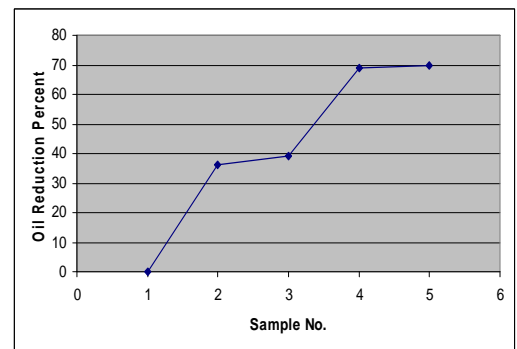

Diagram 6: Oil reduction percent

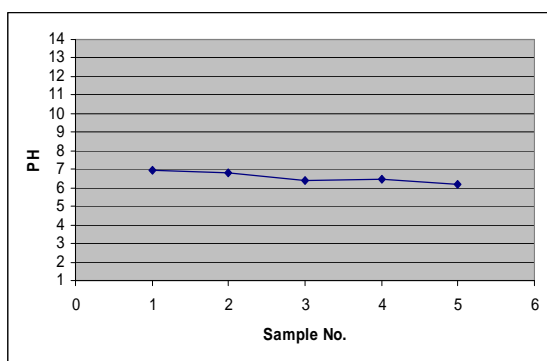

Diagram 7: PH values in each case

5. CONCLUSION

According to the results of this study we get to the following conclusion:

1. Results of samples 4 and 5 shows that adding PAC is effective in flotation process.

2. Compared to sample2, sample 3 has better characteristics that is because of usage of nozzles with smaller diameters, leading to higher mixing energy.

3. Compared to sample4 and two other samples, sample5 has better characteristics that is because of usage of nozzles with smaller diameters combined with adding PAC, resulting in higher mixing energy and more effective flotation.

4. Usage of advanced DAF system (with circular tanks and hydro cyclone) combined with adding PAC reduces TSS to 81%, COD to 67% and oil to 70.1% but has no considerable effect on PH.

5. Using hydro cyclone leads to lower costs by reducing volume of needed air and so a cheaper compressor would be enough and also the number of necessary pumps decreases too.

-
- [1]. Tchobanoglous, g. et al, "Wastewater Engineering", Metcalf & eddy Inc, McGraw Hill, New York, 1991.
- [2]. A. Jarsarayi Talar, "Identification of Design Parameters of Wastewater Treatment in Wood and Paper Manufacturing in Iran Using Physical, Chemical and Biological Pilot", Mse. thesis, Civil eng. Environmental eng., Tarbiyat Modarres University, Engineering faculty, 1377.
- [3]. S. M. J. Hoseyni, "Physucal and Chemical Treatment of Iran's Fiber Factory's Wastewater Using DAF System", Mse. thesis, Civil eng. Environmental eng., Tarbiyat Modarres University, Engineering faculty, 1378.
- [4]. Colic, M., Morse, D.E., Morse, W.O., Matherly, T.G., Carty, S. and Miller, J.D., "From air-sparged hydrocyclone to bubble accelerated flotation", 2001.
- [5]. Mitraker, M., Papageorgiou, G., Docoslis, A., Sakell aropoulos, G. "Evaluation of various pretreatment methods for olive oil Mill wastewater" European water pollution control V6 n6 1996 p10-16.
- [6]. Parker, W. J., Monteith, H. D. "Stripping of Voc's from Dissolved air flotation ", environmental progress V15 n2 1996 P73-81.
- [7]. Bratby, J., Jones, G. and Uhte, W., "State- of-practice of DAFT technology – is there still a place for it?", 77th Annual Conference of the Water Environ. Federation, L CD-ROM Conference Proceedings, WEFTEC, New Orleans, 2004.